

V75
ESC 1:50

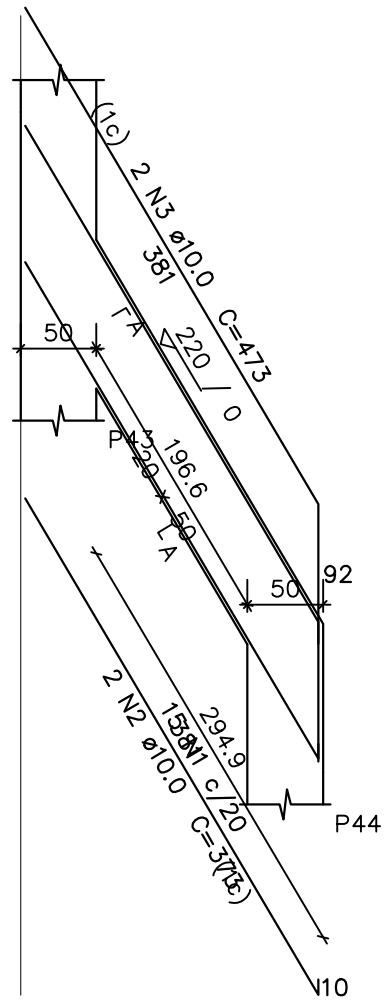

SEÇÃO A-A
ESC 1:25

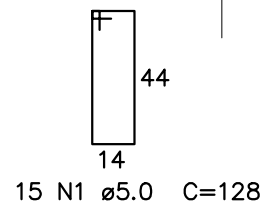
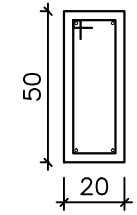

V76
ESC 1:50

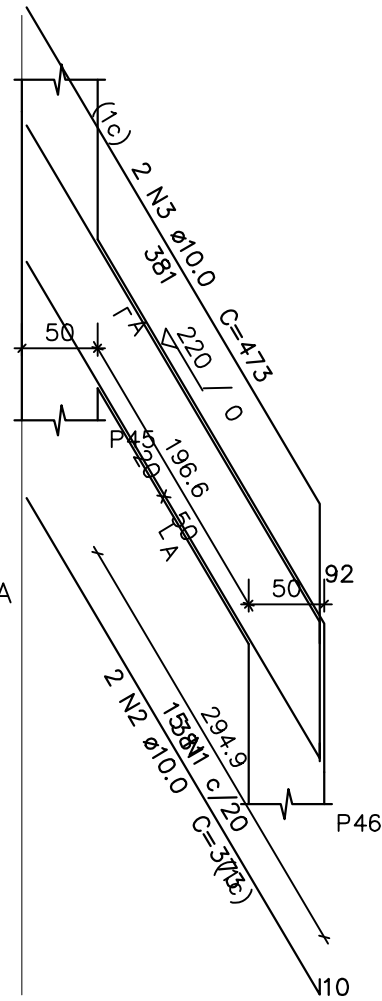

SEÇÃO A-A
ESC 1:25

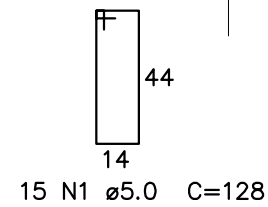
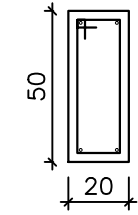

V77
ESC 1:50

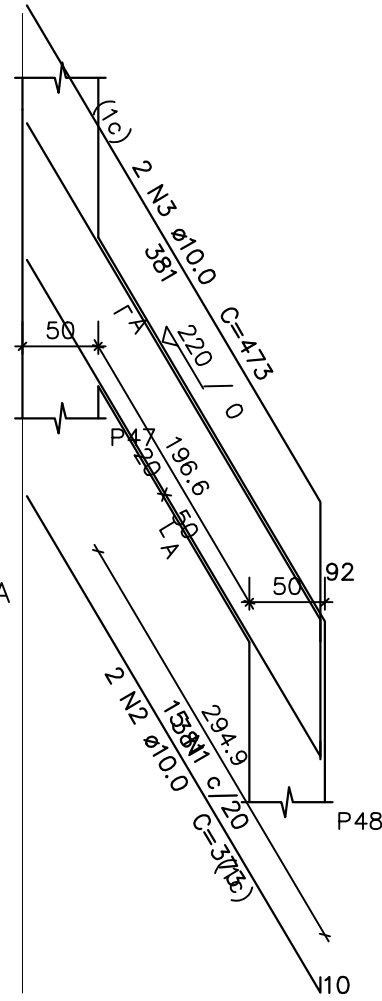

SEÇÃO A-A
ESC 1:25

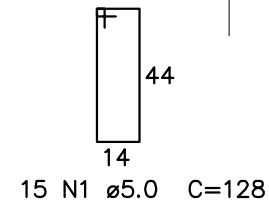
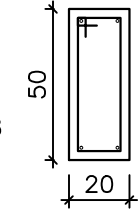

V78
ESC 1:50

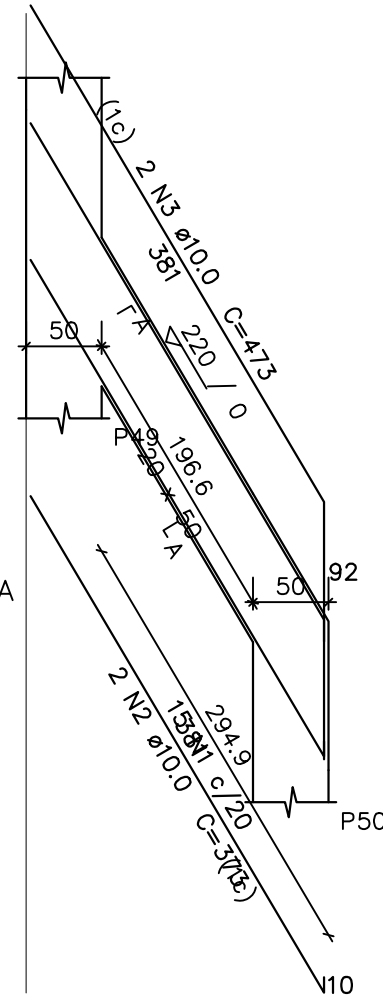

SEÇÃO A-A
ESC 1:25

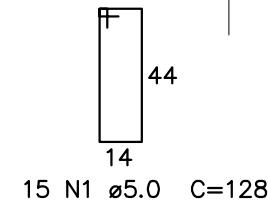
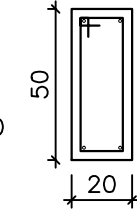

V79
ESC 1:50

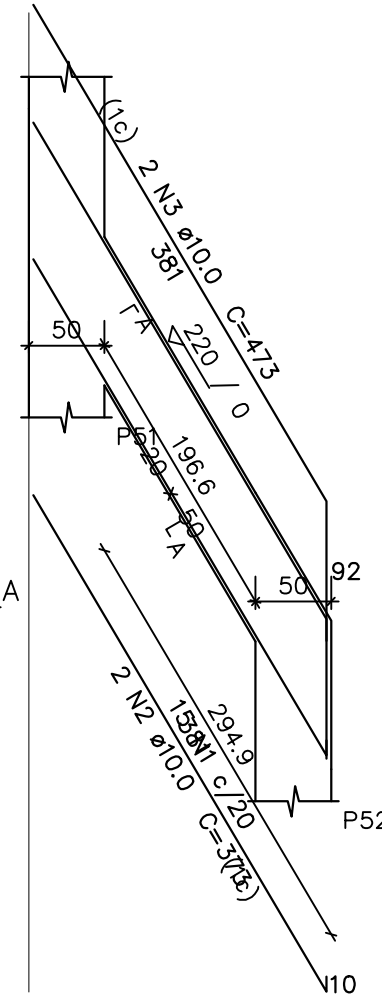

SEÇÃO A-A
ESC 1:25

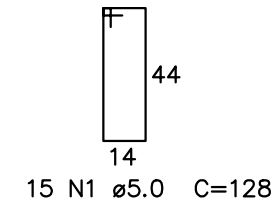
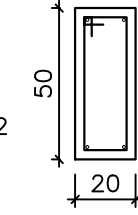

PROJETO:

ESTRUTURAL



APROVAÇÃO:

ITONIR APARECIDO TAVARES
PREFEITO MUNICIPAL

CELSO MARCOS
Secretário de Obras

ÁREA DO TERRENO:

ÁREA CONSTRUÍDA:

Eng° DIEGO LUCENA DE SOUSA
Responsável Técnico
CREA - 1515883191

ESTE DOCUMENTO É DE PROPRIEDADE DO CLIENTE E NÃO PODE SER REPRODUZIDO OU USADO PARA QUALQUER OUTRA FINALIDADE DIFERENTE DAQUELA PARA QUAL ESTA SENDO FORNECIDO SEM A AUTORIZAÇÃO EXPRESSA DO PROJETISTA E DO CLIENTE.

DADOS DO PROJETO:	CLIENTE: PREFEITURA MUNICIPAL DE JACUNDÁ	PRANCHA: EST. 20/24
	OBRA: CONSTRUÇÃO PRAÇA "EU AMO JACUNDÁ"	DATA: AGOSTO/2022
	LOCAL: BAIRRO BOA ESPERANÇA JACUNDÁ-PARÁ	CAD: Eng° DIEGO LUCENA
	ASSUNTO: ARRIMO: DETALHE VIGAS NÍVEL +220.	ESCALA: INDICADA
		VERSÃO: EXECUTIVO