

V60
ESC 1:50

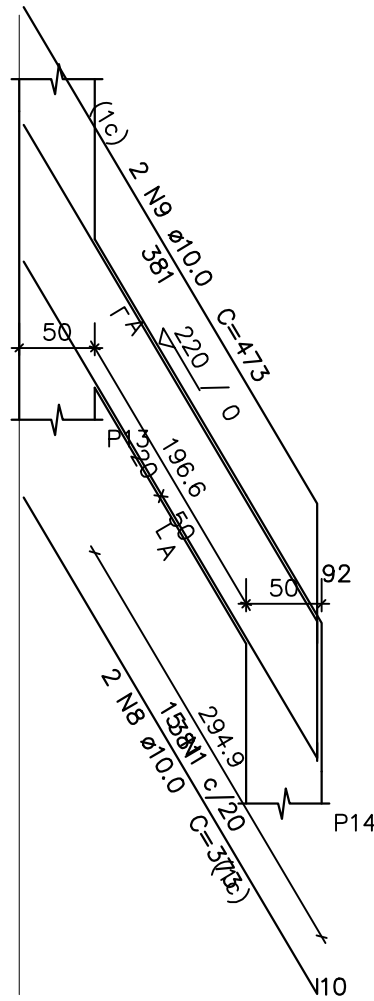

SEÇÃO A-A
ESC 1:25

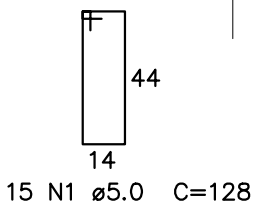
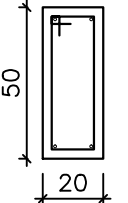

V61
ESC 1:50

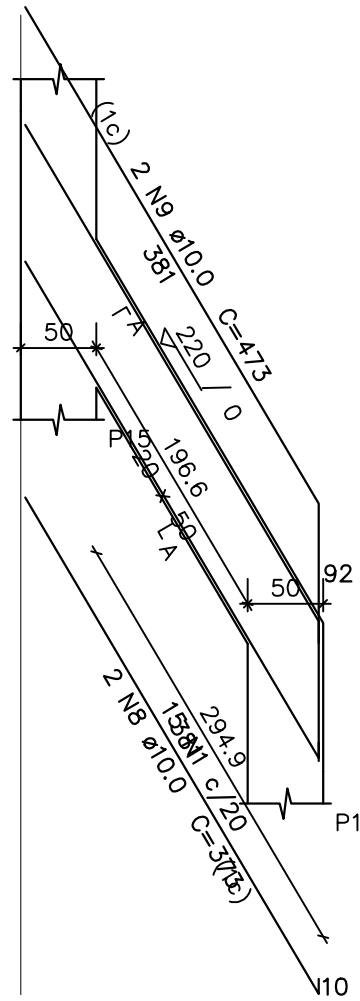

SEÇÃO A-A
ESC 1:25

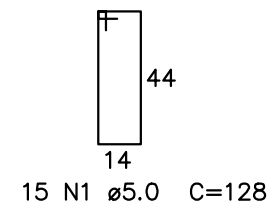
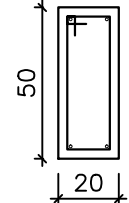

V62
ESC 1:50

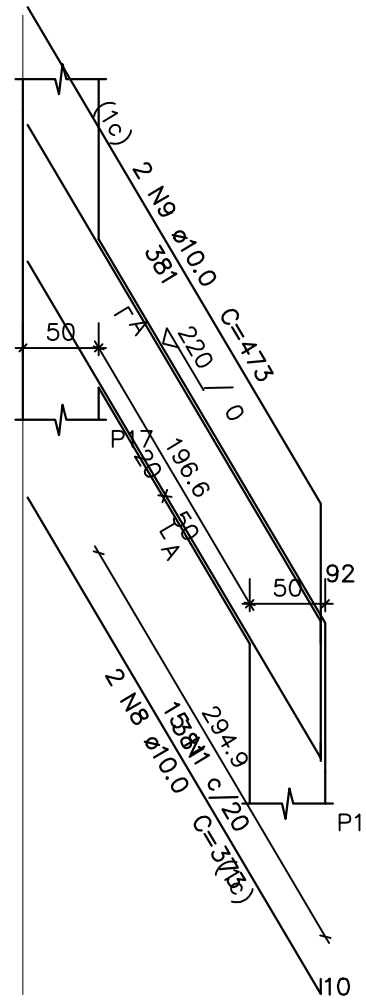

SEÇÃO A-A
ESC 1:25

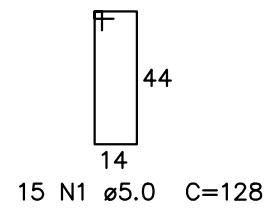
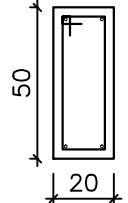

V63
ESC 1:50

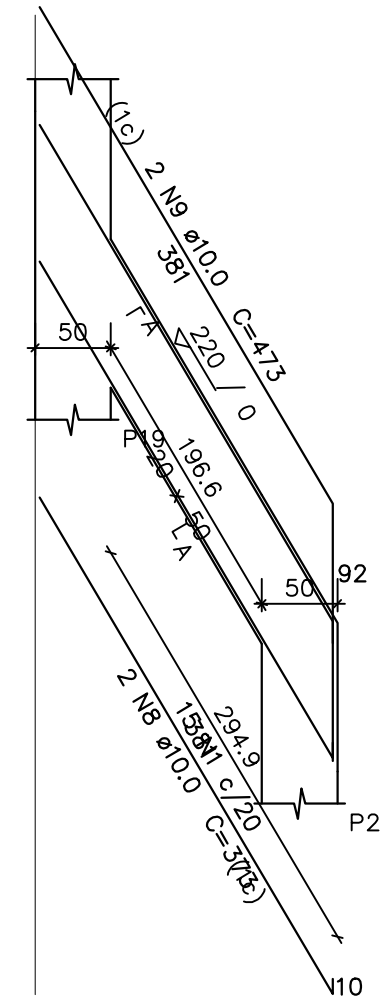

SEÇÃO A-A
ESC 1:25

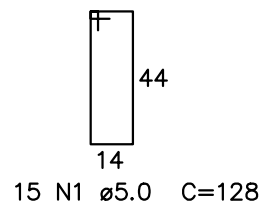
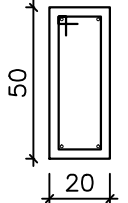

V64
ESC 1:50

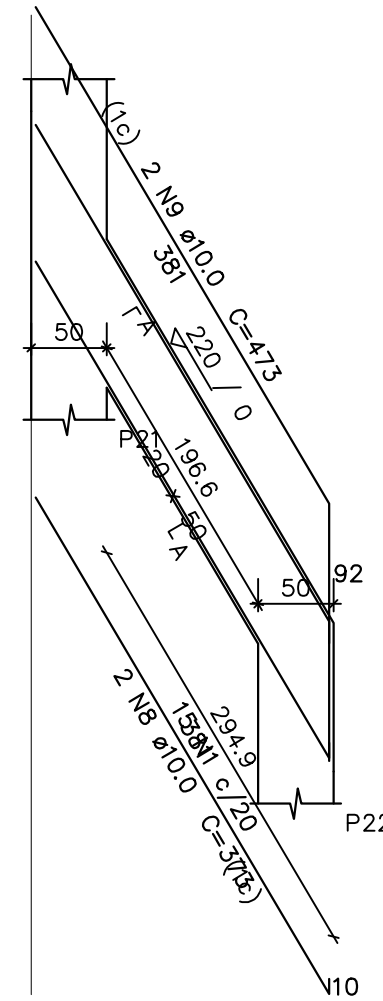

SEÇÃO A-A
ESC 1:25

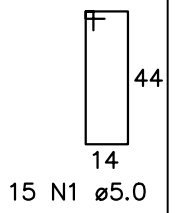
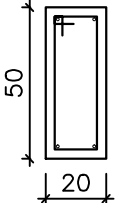

PROJETO: **ESTRUTURAL**



APROVAÇÃO:

ITONIR APARECIDO TAVARES PREFEITO MUNICIPAL	ÁREA DO TERRENO:	ÁREA CONSTRUÍDA:
CELSO MARCOS Secretário de Obras	Engº DIEGO LUCENA DE SOUSA Responsável Técnico CREA - 1515883191	

ESTE DOCUMENTO É DE PROPRIEDADE DO CLIENTE E NÃO PODE SER REPRODUZIDO OU USADO PARA QUALQUER OUTRA FINALIDADE DIFERENTE DAQUELA PARA QUAL ESTA SENDO FORNECIDO SEM A AUTORIZAÇÃO EXPRESSA DO PROJETISTA E DO CLIENTE.

DADOS DO PROJETO:	CLIENTE: PREFEITURA MUNICIPAL DE JACUNDÁ	PRANCHA: EST. 15/24
	OBRA: CONSTRUÇÃO PRAÇA "EU AMO JACUNDÁ"	DATA: AGOSTO/2022
	LOCAL: BAIRRO BOA ESPERANÇA JACUNDÁ-PARÁ	CAD: Engº DIEGO LUCENA
	ASSUNTO: ARRIMO: DETALHE VIGAS NÍVEL +220.	ESCALA: INDICADA
		VERSÃO: EXECUTIVO